

CHASING

CHASING M2 S

Industrial-Grade Underwater ROV

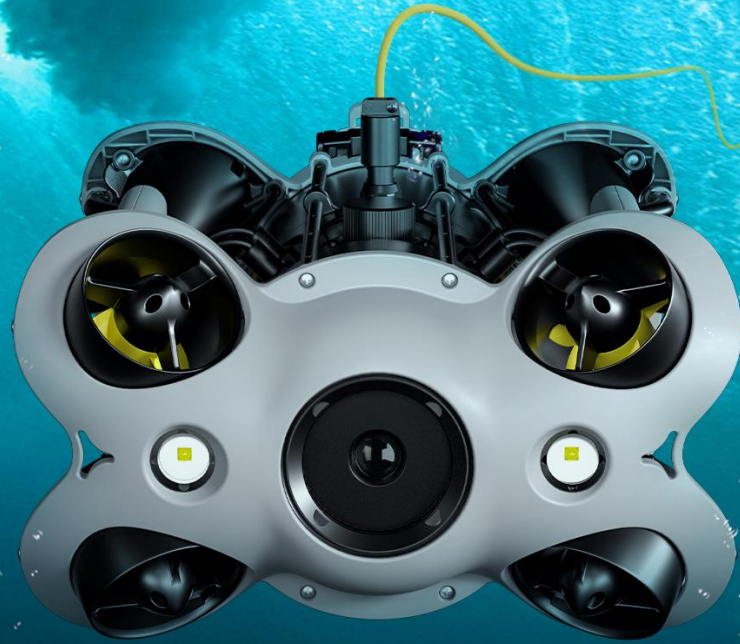

Flexible | Stable | Endless exploration

*The specific parameters and functions are subject to the actual products on the market.

CHASING M2 S

CHASING M2 S is an industrial-grade revolutionary underwater robot, which adopts an open-body design, intelligent flight control system and image algorithm, bringing unprecedented underwater perception and freedom of movement. 8 vectored-thrusters are symmetric and anti-stuck C-Motor 3.0 provide stable power, while the flagship sealed structure guarantees underwater operation performance. The ROV is compact and lightweight, easy to operate, and efficiently completes inspection tasks in various underwater operating scenarios in different industries.



*The specific parameters and functions are subject to the actual products on the market.

THREE MECHANISMS



C-Sense Control System,
flexible and stable



All-scenario Efficient
Operation System



HD Visual Image
Transmission System

C-Sense control system, flexible and stable



8 Vectored-thrusters

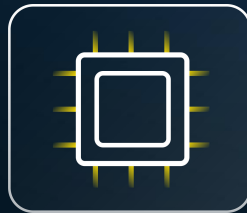

NeptuneX intelligent flight control system



Apex Anti-stuck C-Motor 3.0



Flagship Airtight structure



Butterfly wing outline

8 *Vectored-thrusters*

- | Remains the symmetrical vector layout of the eight thrusters of CHASING.
- | Adopts a design where translation and rotation are independent of each other.
- | Supports 360-degree omnidirectional movement and rotation.



Improves posture response speed and control stability.



NeptuneX intelligent flight control system

The exclusive CHASING navigation algorithm enables more precise operation; CHASING M2 S can maintain the movement direction even in the presence of external force interference or difficult operating conditions.



*The specific parameters and functions are subject to the actual products on the market.

NeptuneX intelligent flight control system

The Kalman inertial navigation fusion depth observation method greatly reduces the impact of ocean waves on ROV and maintains the depth stable, significantly enhances the vertical flow resistance capability.

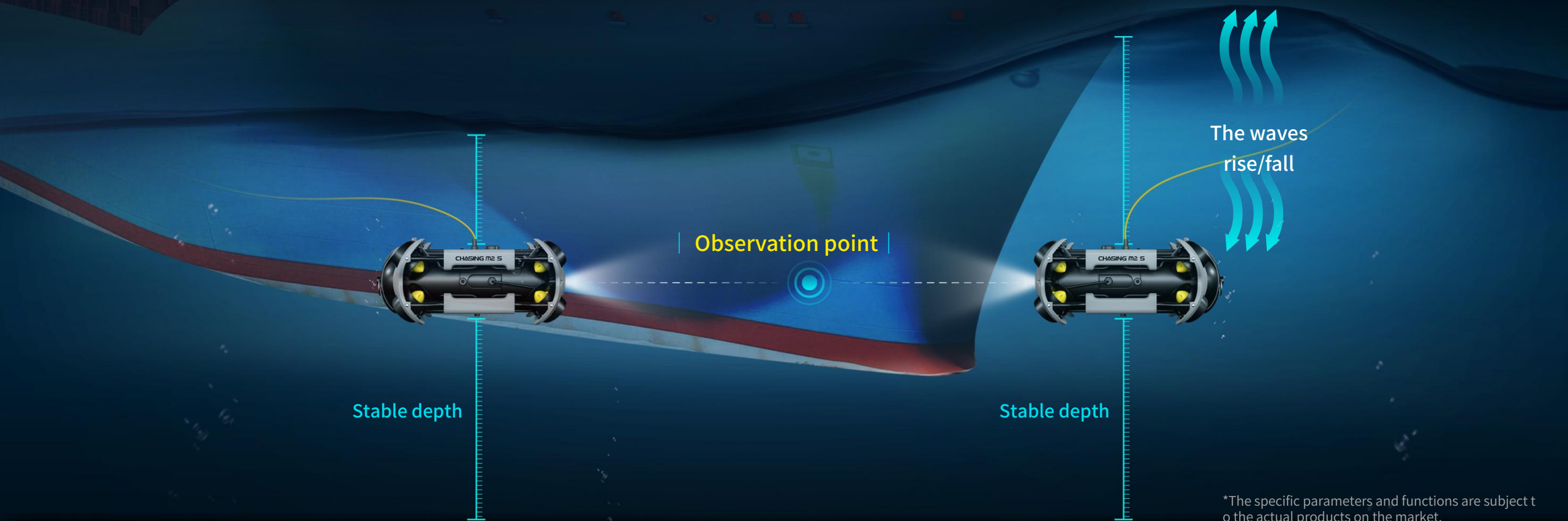
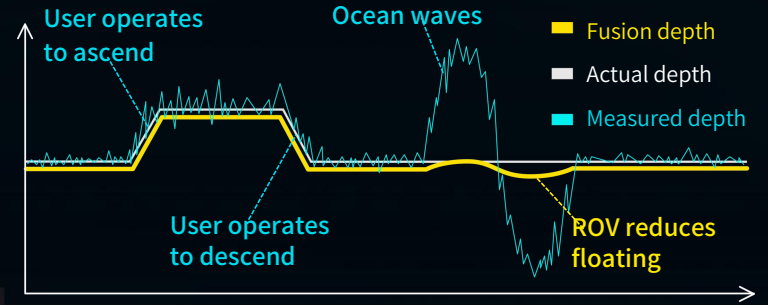

*The specific parameters and functions are subject to the actual products on the market.

Apex Anti-stuck C-Motor 3.0

The third-generation Apex Anti-stuck C-Motor 3.0 used in the CHASING M2 S adopts a unique anti-stuck solution and magnet protection technology, which ensures power supply but also greatly reduces electrochemical corrosion and aggregation rust caused by motor wear. The anti-stuck performance is stronger, making it more reliable to use.

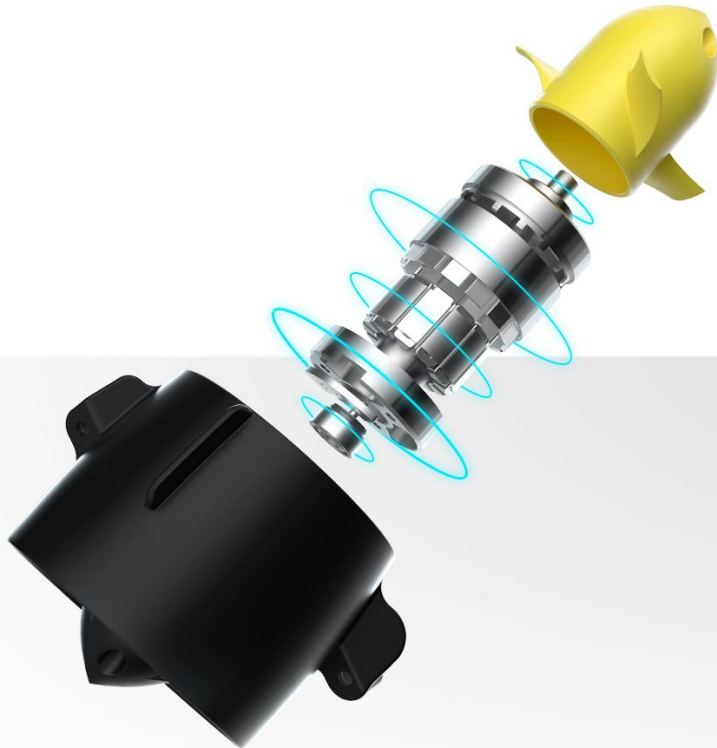

Flagship Airtight structure

Fully innovate the waterproof structure of the main cabin and lighting to further enhance the stability of underwater operations.



*The specific parameters and functions are subject to the actual products on the market.

*The specific parameters and functions are subject to the actual products on the market.

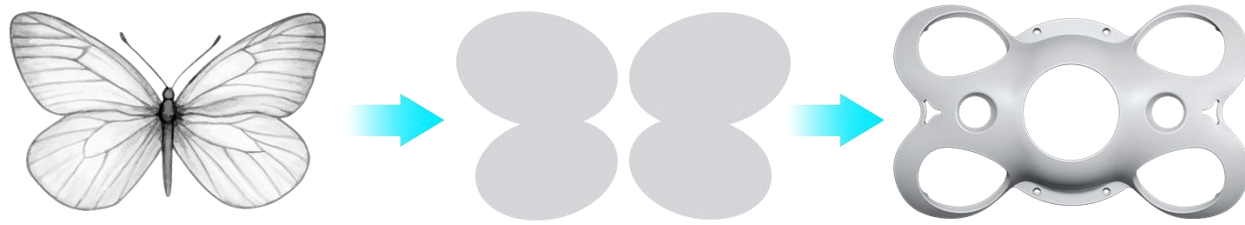

Butterfly wing outline

The streamlined design of the butterfly wing outline at front and rear enhances the recognition and protects the propeller.



All-scenario Efficient Operation System



A wide
working range



Multiple
accessories



All scenarios
application

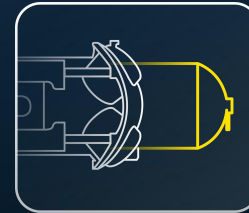

Swappable
battery

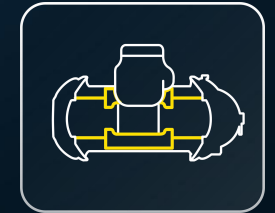

Portable
and convenient

A wide working range

CHASING M2 S can dive to a maximum depth of 100 meters, an operating radius of 200 meters. 400 meters extendable distance.



100m
Maximum depth to dive

400m

Maximum movement radius

200m

Movement radius



Multiple accessories

CHASING
FLOODLIGHT 2



CHASING Grabber Arm 2

GoPro



DIY Fish net

| Adapt to CHASING self-developed accessories |



CHASING LASER
Scaler

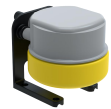

CHASING DISTANCE
LOCK SONAR



CHASING
WSRC

| Suitable for third-party facilities |

All scenarios application

CHASING M2 S is widely applied in various industries, such as underwater photography, hull and dock inspection, fishery and aquaculture monitoring, underwater emergency rescue, scientific exploration, water conservancy and hydropower inspection, Pipeline inspection, providing efficient solutions for underwater observation tasks.

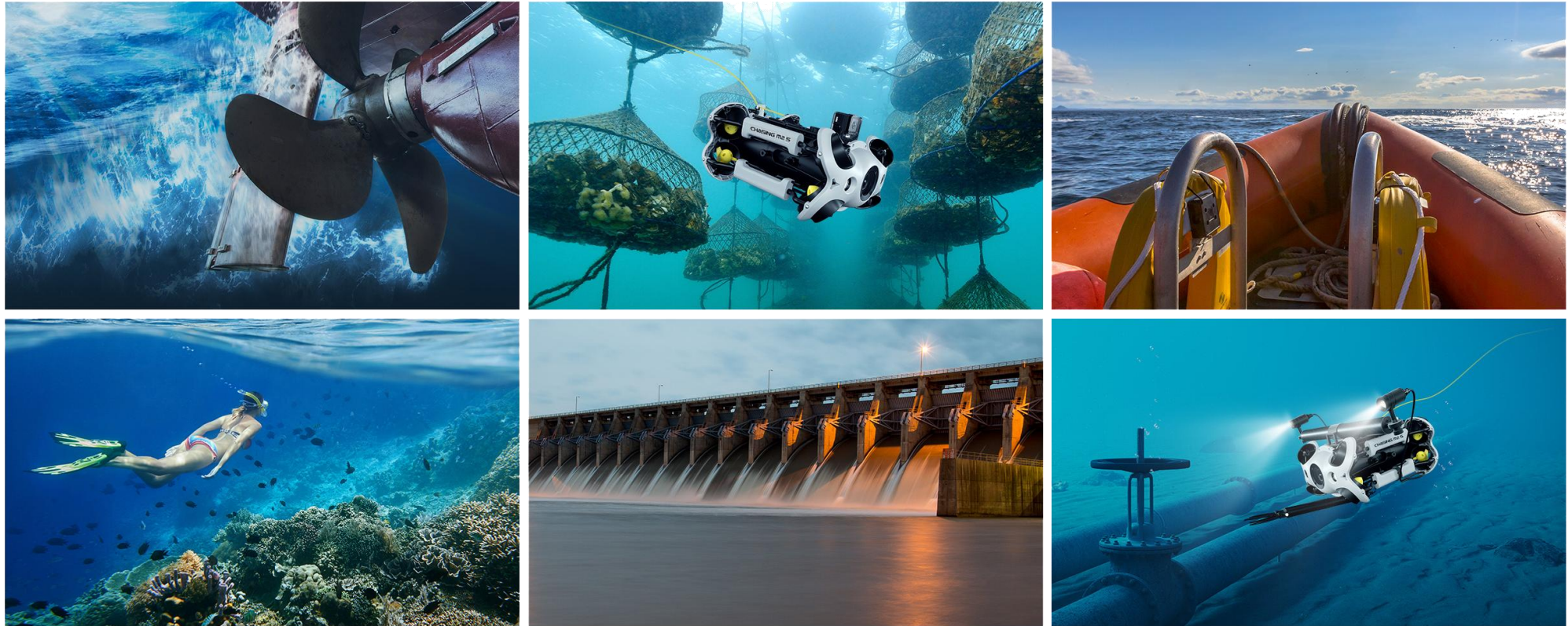

*The specific parameters and functions are subject to the actual products on the market.

Swappable battery

CHASING M2 S has a default 97.68Wh battery that can power up to 4 hours operation.
The battery compartment is ready to use, 200Wh backup battery is also optimal to meet the needs of long-time operation.

97.68Wh

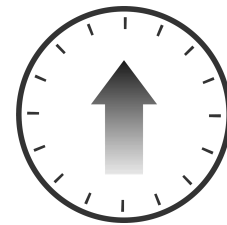
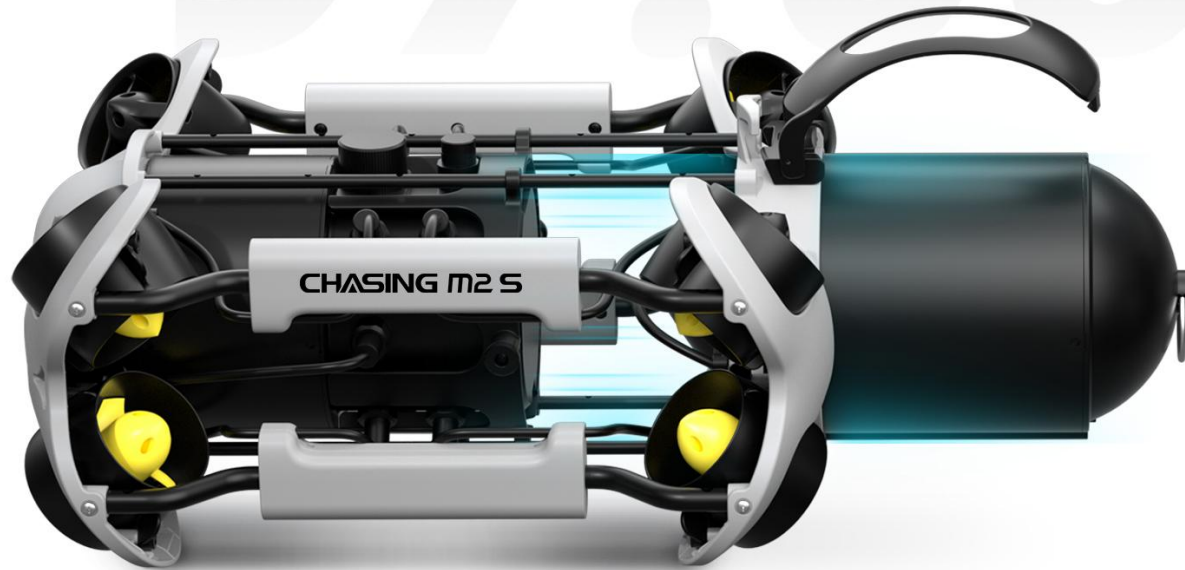

Extend operation time

- | The battery compartment is ready to use
- | Optional 200Wh backup battery

Portable and convenient

CHASING M2 S is portable and has a compact body. Single-person operation and quick deployment brings an effective operating experience under a variety of scenarios.



Body weights <math><5\text{kg}</math>



*The specific parameters and functions are subject to the actual products on the market.

HD Visual image Transmission System



4K+EIS Image Stabilization,
F2.8 Aperture



CHASING Aquavision image
algorithm, fully upgraded
imaging



Removable SD
memory card , online
live-stream and share



User-friendly
interaction

4K+EIS Image Stabilization, F2.8 Aperture

Clearly capture every detail underwater



4K Video



12 Megapixel



1/2.3 SONY
CMOS



F2.8 Aperture



EIS



4000lm LED
Floodlights

*The specific parameters and functions are subject to the actual products on the market.

CHASING Aquavision image algorithm, fully upgraded imaging

The color restoration algorithm design based on underwater light, physical light route, and environmental, as well as the visual identification and tracking system, completely upgrade image transparency, clarity, reducing color layering, and noise.

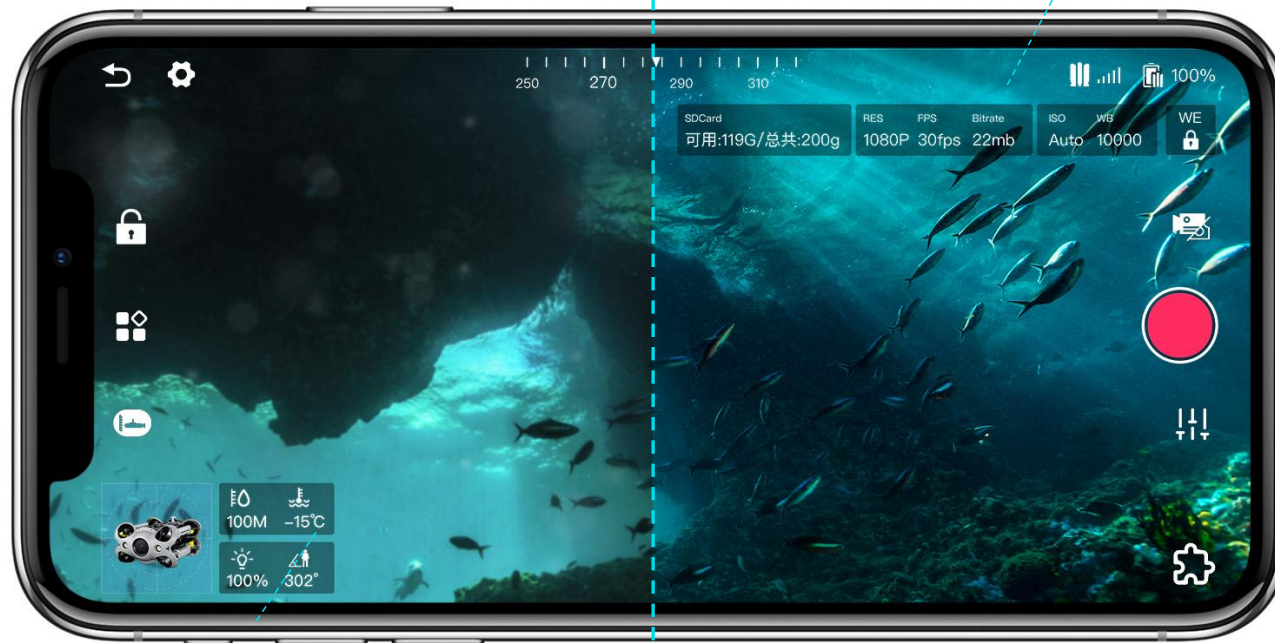

| Before |

| After |



*The specific parameters and functions are subject to the actual products on the market.

Removable SD memory card to save photos and videos, Support online live-stream and share



The **64G** SD memory card is removable, up to **512G**.



Live-stream



Social media sharing



HDMI output



Take pictures while recording video



Time-lapse photography



Quick editing tools

*The specific parameters and functions are subject to the actual products on the market.

User-friendly interaction

Easy to interact between operator and ROV. Professional remote controller and CHASING App. The operator can record depth, temperature, and other parameters.



| Support VR

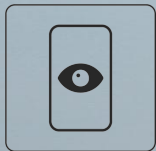

| Observer mode



| Multiple devices watching



*The specific parameters and functions are subject to the actual products on the market.

Product parameter

ROV

SIZE	380*267*165mm
WEIGHT	4.5KG
MAX DEPTH	100m
RUNTIME	4 H
BATTERY	97.68Wh
OPERATING TEMPERRATURE	-10°C~45°C

Remote Controller

SIZE	160*155*125mm
WEIGHT	685g
BATTERY	2500mAh
RUNTIME	≥6H(depending on the environment)
WIRELESS	Wi-Fi Supported
HDMI	Supported
HANDLE SPRING	Maximum support 10 inch

Camera

CMOS	1/2.3
LENS	F2.8
FOCUS	3.2mm
ISO RANGE	100-6400
FOV	150°
MAX RESOLUTION	12 MegaPixel
FORMAT	JPEG/DNG
VIDEO	UHD:3840*2160 (4K) 30fps FHD:1920*1080 (1080p) 30/60/120fps
SLOW MOTION	720p: 8x (240fps) 1080p: 4x (120fps)
TIME LAPSE	4K/1080p supported
VIDEO STREAM	60M
VIDEO FORMAT	MP4
SD Card	Default 64G (Maximum 512G)

LED

BRIGHTNESS	2*2000 Lumens
COLOR TEMPERATURE	5000K~5500K
CRI	85
DIMMING	THREE GEARS

SENSOR

IMU	axis gyro/accelerometer/ compass
DEPTH SENSOR	< ±0.25m
TEMPERATURE SENSOR	< ±2°C

CHARGER

POWER	2.9A/25.2V
ROV CHARGING TIME	2.5H
RC CHARGING TIME	2H

CHASING

CHASING M2 S

Industrial-Grade Underwater ROV

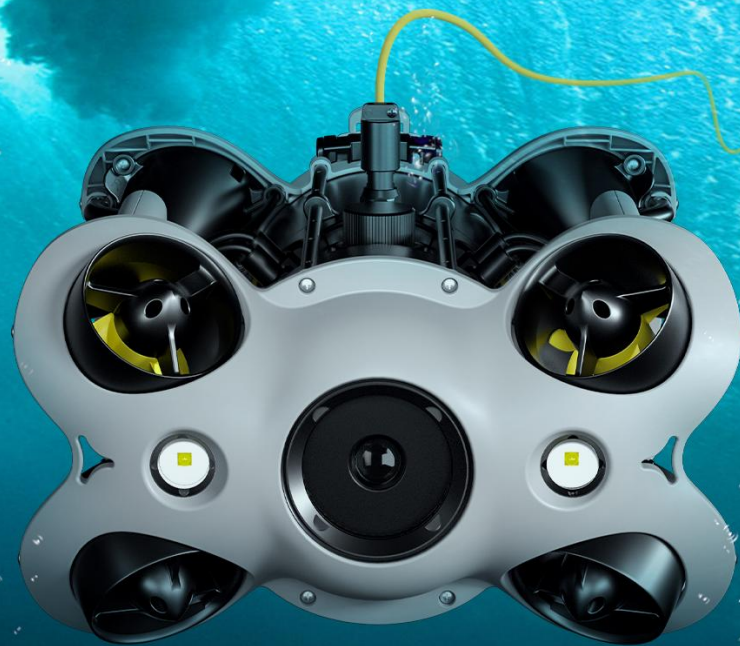

Flexible | Stable | Endless exploration

*The specific parameters and functions are subject to the actual products on the market.